

# Antennas for Trains and Buses

More than 50 years experience in train antennas



**KATHREIN**

Antennen · Electronic

**Photo on title page:** Train antennas in the past and now (high-speed maglev train in Shanghai).

**Catalogue Issue 08/2006**

All data published in previous catalog issues hereby becomes invalid.

We reserve the right to make alterations in accordance with the requirements of our customers.

**Please note:**

**The details given in our data sheets have to be followed carefully when installing the antennas and accessories.**

**The installation team must be properly qualified and also be familiar with the relevant national safety regulations.**



**“Quality leads the way”**

As the world’s oldest and largest antenna manufacturer, we live up to claim “Quality leads the way” on a daily basis. One of the fundamental principles is to always be on the lookout for the best solution for our customers.

Our quality assurance system and our environmental management system apply to the entire company and are certified by TÜV according to EN ISO 9001 and EN ISO 14001.





Munich city tram

# Summary

## Antennas for trains and buses

### 68 ... 2700 MHz

Frequency band	Type No.	Operating frequency range	Type approved by "Deutsche Bahn AG"	Remarks	Page
4m-band	K 50 21 41	Tunable in the range 68 ... 87.5 MHz	Yes		6
FM radio	727 313	87.5 – 108 MHz	Yes	Only for receiving	7
2m-band	K 50 21 22	Tunable in the range 146 ... 174 MHz	Yes	Low profile	8
	K 50 22 21 . K 50 22 22 .	146 – 156 MHz 156 – 174 MHz		Low profile	9
	733 707	146 – 172 MHz	Yes		10
2m-/70cm-band	731 495	165 – 174 MHz 457.4 – 468.3 MHz		Two-band antenna	11
70cm-band	870 10008 <b>new</b>	380 – 430 MHz	Yes		12
	K 70 23 2 . .	406 ... 470 MHz		Low profile	13
	K 70 20 21	410 – 470 MHz	Yes		14
	725 892 K 70 21 21	410 – 430 MHz 450 – 470 MHz	Yes	Gain 2 dB	15
	729 003	444 – 461.5 MHz		Special radome	16
	721 232	457 – 470 MHz		Special radome	16
70cm-band 800/900 MHz	K 70 20 61	450 – 470 MHz 806 – 960 MHz	Yes	Two-band antenna	17
	870 10009 <b>new</b>	430 – 470 MHz 870 – 960 MHz	Yes	Two-band antenna	18
900 MHz	741 009	870 – 960 MHz	Yes	Special radome	19
	K 70 21 63 1	876 – 960 MHz	Yes	Gain 3.5 dB	20
800/900/1800 MHz / UMTS / WLAN / WIMAX	870 10007 <b>new</b>	806 – 2700 MHz	Yes	Low profile	21

### Antennas with integrated GPS-Module

70cm-band / GPS	870 10005 <b>new</b>	380 – 430 MHz 1575.42 ± 1 MHz	Yes		22
70cm-band / 900 MHz / GPS	870 10006 <b>new</b>	430 – 470 MHz 870 – 960 MHz 1575.42 ± 1 MHz	Yes		23
800/900/1800 MHz / UMTS / WLAN / WIMAX / GPS	870 10003 <b>new</b>	806 – 2700 MHz 1575.42 ± 1 MHz	Yes	Low profile	24
GPS	860 10069 <b>new</b>	1575.42 ± 1 MHz		Low noise amplifier	25

Installation Guidelines see from page 26 onwards

Additional antenna types available on request. Please contact:  
antennas.mobilcom@kathrein.de

## Article summary

The articles are listed by type number  
in numerical order

---

Type No.	Page
721 232	16
725 892	15
727 313	7
728 954	17
729 003	16
731 495	11
732 997	13
733 707	10
741 009	18
790 244	11
860 10069	25
870 10003	24
870 10005	22
870 10006	23
870 10003	21
870 10008	12
870 10009	18
K 50 21 41	6
K 50 21 22	8
K 50 22 21 1	9
K 50 22 21 2	9
K 50 22 22 1	9
K 50 22 22 2	9
K 70 20 21	14
K 70 20 61	17
K 70 21 21	15
K 70 21 63 1	19
K 70 23 21	13
K 70 23 21 0	13
K 70 23 21 1	13
K 70 23 23	13
K 70 23 23 0	13
K 70 23 23 1	13

# Train Antenna

## 68 ... 87.5 MHz

### K 50 21 41

- Aluminum antenna in fiberglass radome.
- Fully tunable in the 68 ... 87.5 MHz range.

Type No.	K 50 21 41
Input	N female
Frequency range	68 ... 87.5 MHz
Impedance	50 Ω
Polarization	Vertical
Max. power	100 W (at 50 °C ambient temperature)
Weight	5.3 kg
Packing size (outside)	502 x 162 x 370 mm

- Material:** Radiator and base: Aluminum.  
Radome: Fiberglass; Colour: Grey.
- Mounting:** On a conductive surface 200 x 100 cm min. with 3 studs M10.
- Tuning:** The antenna can be tuned to the transmitter frequency in the range 68 ... 87.5 MHz by two tuning screws.
- Grounding and high voltage protection:** This antenna approved by the "Deutsche Bahn AG" is D.C. grounded to protect against lightning and high-tension lines.
- Special features:** After mounting the antenna can be turned  $\pm 30^\circ$  when the mounting elements are still loose. The tuning screws are inside the fiberglass cover and easily accessible from the outside by means of plastic caps.
- Scope of supply:** Antenna and watertight ring (O-seal).

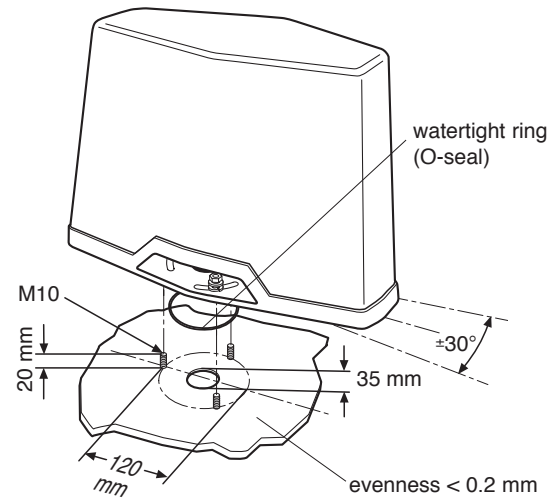
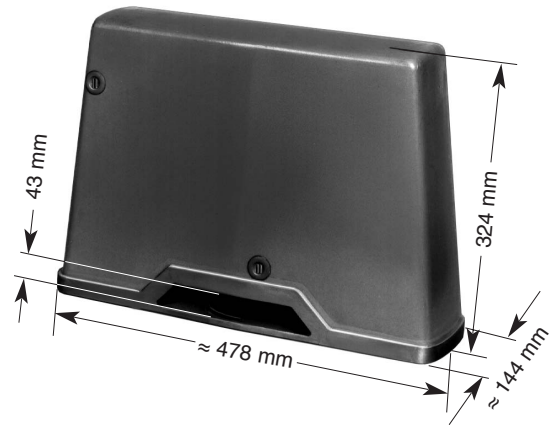

#### Typical Standing Wave Ratio (VSWR)

Examples for tuning to different frequencies measured against a 2 x 1 m conductive plane.

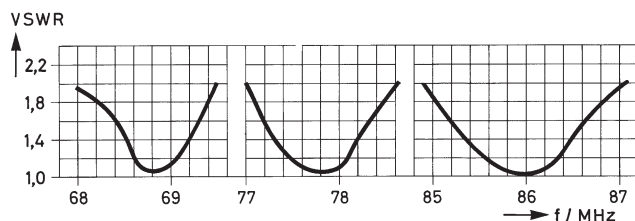

Welding flange:

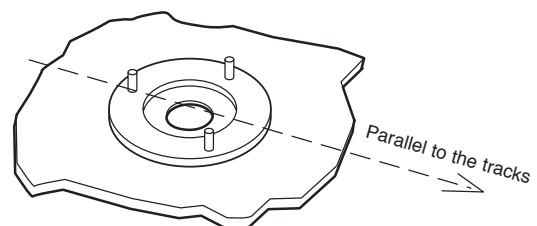



# Train Antenna

## 87.5 – 108 MHz

### 727 313

- FM-broadcast receiving antenna for rail vehicles in fiberglass radome.
- Only for receiving.

Type No.	727 313
Input	N female
Frequency range	87.5 – 108 MHz
Impedance	50 Ω
Polarization	Vertical
Weight	0.9 kg
Packing size (outside)	151 x 90 x 415 mm

Material: Flange: Aluminum.  
Radiator: Copper.  
Radome: Fiberglass; Colour: Light grey.  
All screws and nuts: Stainless steel.

Mounting: On a conductive surface with a minimum size of 100 x 200 cm by means of existing M10 studs.

Grounding and high voltage protection: This antenna approved by the "Deutsche Bahn AG" is D.C. grounded to protect against lightning and high-tension lines.

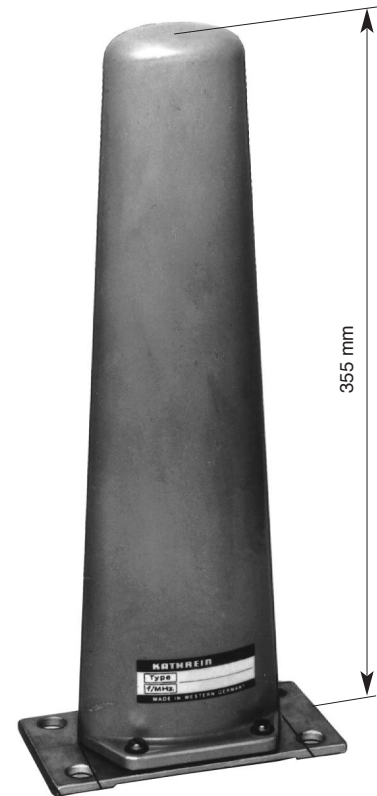

Mounting flange:

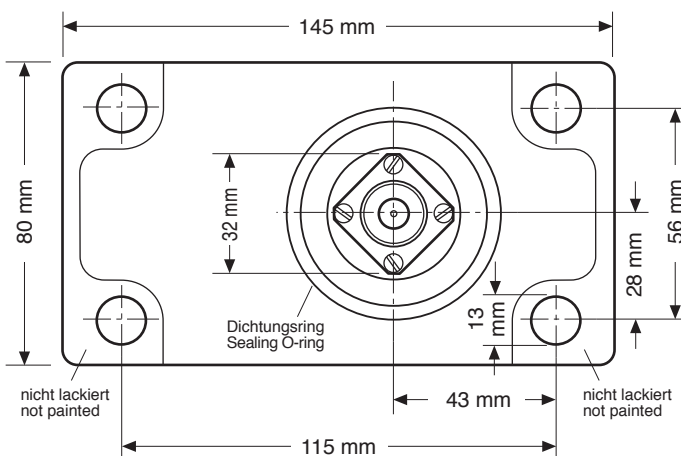

Mounting hole for the connector: 33 (max. 35) mm diameter.

**Note:** Keep mounting surface clear of paint for electrical contact.

# Low Silhouette Train Antenna

## 146 ... 174 MHz

### K 50 21 22

**KATHREIN**  
Antennen · Electronic

- Tunable antenna.
- Hot dip galvanized steel.

Type No.	K 50 21 22
Input	UHF female
Frequency range	146 ... 174 MHz
Impedance	50 Ω
Antenna efficiency	> 0.95
Polarization	Vertical
Max. power	100 W (at 50 °C ambient temperature)
Weight	3.3 kg
Packing size (outside)	232 x 172 x 305 mm

- Material:** Radiator and base: Hot dip galvanized steel.  
Tuning screws: Brass, nickel plated.  
Colour: Unpainted zinc surface.
- Mounting:** On a conductive surface 100 x 100 cm min. with 4 studs M10 and counterflange.
- Tuning:** With two tuning screws the antenna can be set to the transmitter frequency.
- Grounding and high voltage protection:** This antenna approved by the "Deutsche Bahn AG" is D.C. grounded to protect against lightning and high-tension lines.
- Scope of supply:** Antenna with 4 studs, each with 2 nuts, 1 rubber gasket and 1 counterflange.

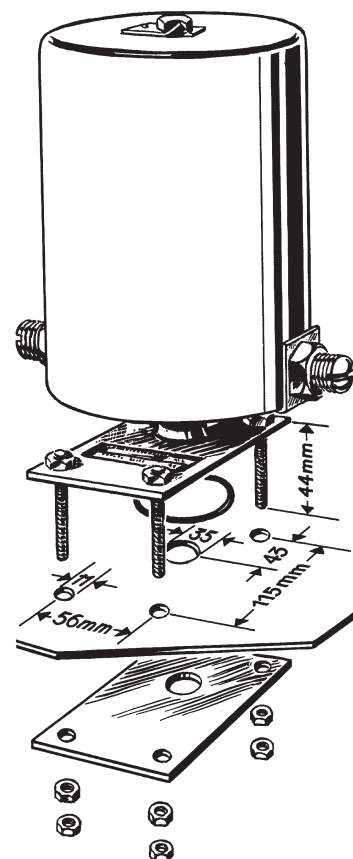
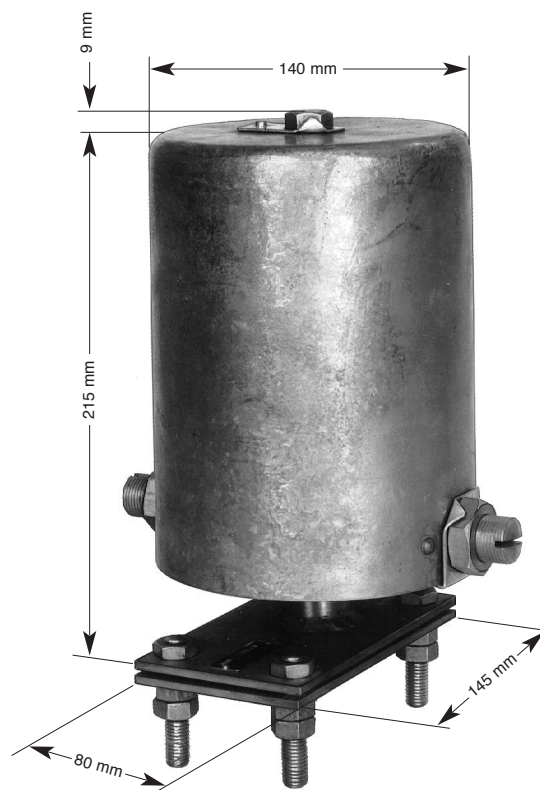



# Train Antenna

## 146 ... 174 MHz

### K 50 22 2. .

- Broadband antenna in fiberglass radome.

Type No.	K 50 22 21 1	K 50 22 21 2
Input	N female	UHF female
Frequency range	146 – 156 MHz	
VSWR	< 1.4	
Impedance	50 Ohm	
Polarization	Vertical	
Max. power	100 W (at 50° C ambient temperature)	
Weight	1.2 kg	
Packing size (outside)	262 x 262 x 145 mm	

Type No.	K 50 22 22 1	K 50 22 22 2
Input	N female	UHF female
Frequency range	156 – 174 MHz	
VSWR	< 1.4	
Impedance	50 Ohm	
Polarization	Vertical	
Max. power	100 Watt (at 50° C ambient temperature)	
Weight	1.2 kg	
Packing size (outside)	262 x 262 x 145 mm	

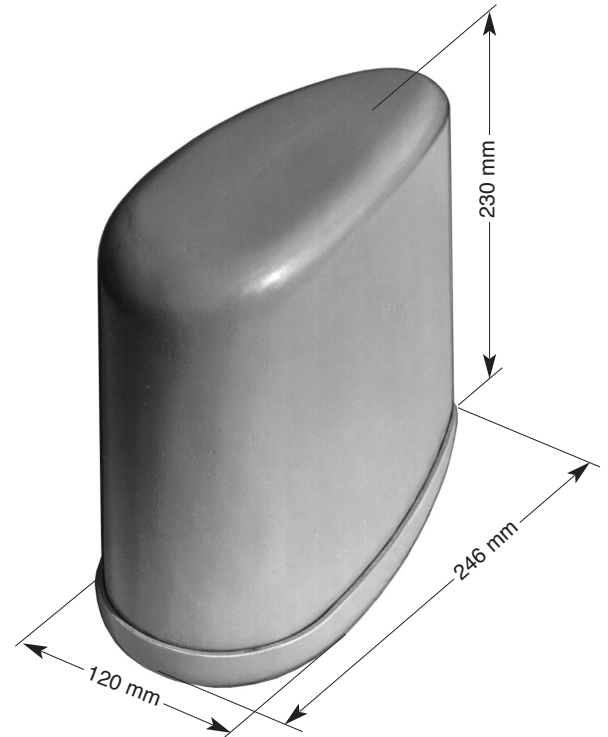

**Material:** Radiator and Base: Aluminum.  
Radome: Fiberglass, colour: Grey.  
Studs and all screws and nuts: Stainless steel.

**Mounting:** On a conductive surface 100 x 100 cm min. with 3 studs M10 and counterflange.  
**Note:** No superstructures in this area.

**Grounding and high voltage protection:** D.C. grounded to protect against lightning and high-tension lines.

**Scope of supply:** Antenna with 3 studs, each with 2 nuts, 1 rubber gasket and 1 counterflange.

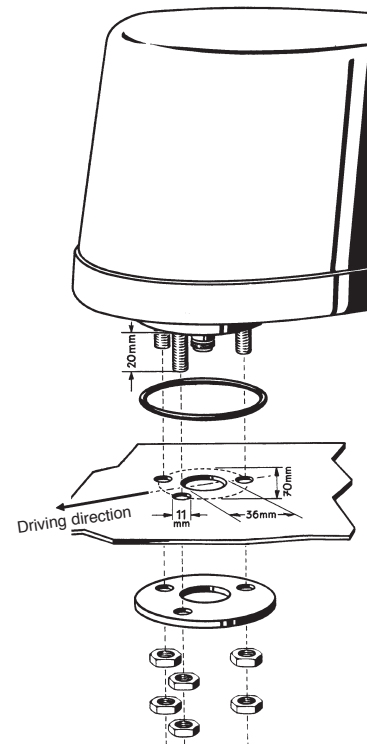

# Train Antenna

## 146 – 172 MHz

### 733 707

- Aluminum antenna in fiberglass radome.

Type No.	733 707
Input	N female
Frequency range	146 – 172 MHz
VSWR	< 2.0
Gain	0 dB (ref. to the quarter-wave antenna)
Impedance	50 Ω
Polarization	Vertical
Max. power	100 W (at 50 °C ambient temperature)
Weight	0.8 kg
Packing size (outside)	151 x 90 x 415 mm

**Material:** Radiator and Flange: Aluminum.  
Radome: Fiberglass, colour: Light grey.  
All screws and nuts: Stainless steel.

**Mounting:** On a conductive surface 100 x 100 cm min.  
with 4 studs M10.

**Grounding and high voltage protection:** This antenna approved by the "Deutsche Bahn AG" is D.C. grounded to protect against lightning and high-tension lines.

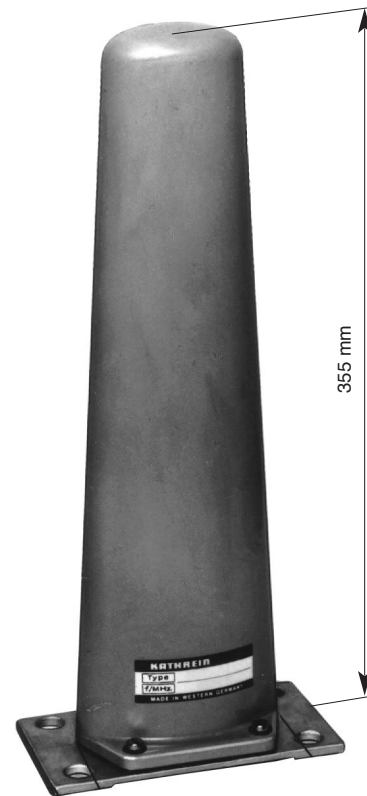

**Mounting flange:**

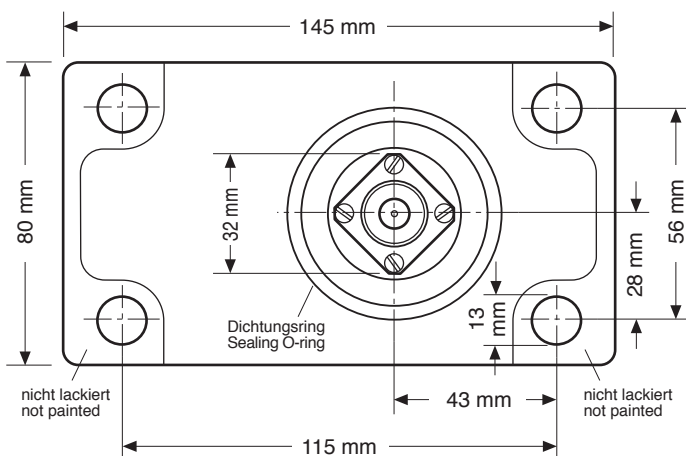

**Mounting hole for the connector:** 33 (max. 35) mm diameter.  
**Note:** Keep mounting surface clear of paint for electrical contact.

# Train Antenna

## 165 – 174 MHz and 457.4 – 468.3 MHz 731 495

- Two-band antenna in fiberglass radome.
- The antenna can be operated in both frequency ranges simultaneously by using the combiner 790 244.

Type No.	731 495
Input	N female
Frequency range	165 – 174MHz   457.4 – 468.3 MHz
VSWR	< 1.6
Gain	0 dB   2 dB (ref. to the quarter-wave antenna)
Impedance	50 Ω
Polarization	Vertical
Max. power	10 W (at 50 °C ambient temperature)
Weight	0.8 kg
Packing size (outside)	151 x 90 x 415 mm

Material:	Radiator and flange: Aluminum. Radome: Fiberglass; Colour: Light grey. All screws and nuts: Stainless steel.
Mounting:	On a conductive surface 100 x 100 cm min. with 4 studs M10.
Grounding and high voltage protection:	This antenna is D.C. grounded to protect against lightning and high-tension lines.

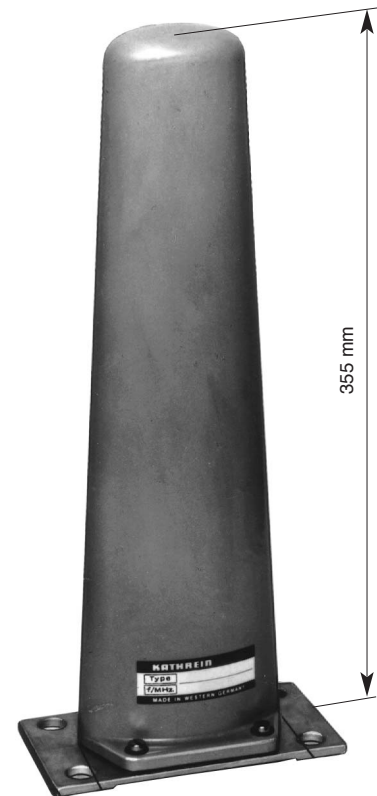

### Accessories: Combiner (order separately)

Type No.	790 244
Input	3 x N female
Frequency range:	
4 m- and 2 m-band	68 – 174 MHz
70 cm-band	400 – 470 MHz
Impedance	50 Ω
Insertion loss	< 0.5 dB
Coupling loss	> 35 dB

Mounting flange:

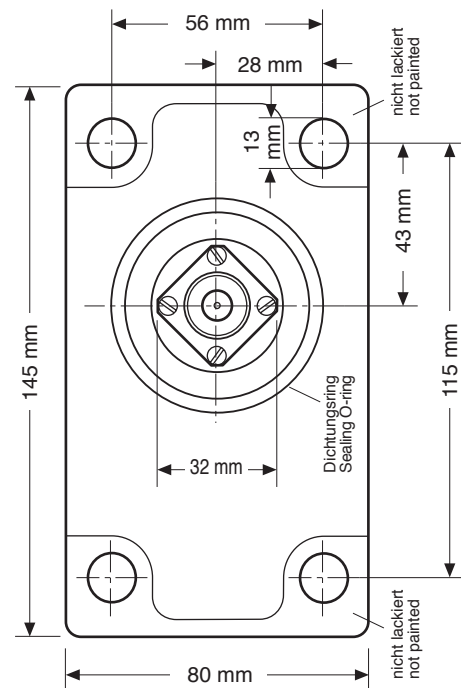

Mounting hole for the connector:  
33 (max. 35) mm diameter.

**Note:** Keep mounting surface clear of paint for electrical contact.

# Train Antenna

## 380 – 430 MHz

### 870 10008

- Low profile antenna in fiberglass radome.
- The antenna fulfils the requirements according to EN 50155.

Type No.	870 10008
<b>Antenna</b>	
Input	N female
Frequency range	380 – 430 MHz
VSWR	< 1.7
Gain	0 dB (ref. to the quarter-wave antenna)
Impedance	50 Ω
Polarization	Vertical
Max. power	100 W (at 50° C ambient temperature)
Inner conductor	D.C. grounded
Weight	Approx. 0.5 kg
Packing size, L x W x H	150 x 90 x 190 mm
Height	150 mm

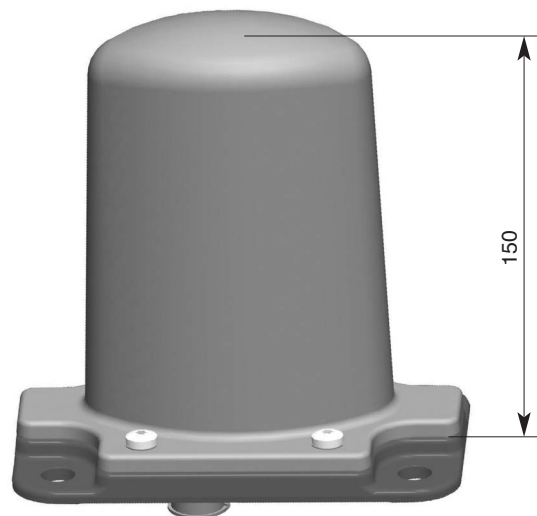

- Material:** Radiator: Copper and brass.  
Flange: Aluminum. Radome: Fiberglass.  
All screws and nuts: Stainless steel.  
Colour: Grey.
- Mounting:** On a conductive surface with a minimum size of 1000 x 1000 mm by cap nut only on 4 existing M10 studs.
- Grounding:** This antenna is D.C. grounded to protect against lightning and high-tension lines.  
Approval according to "Deutsche Bahn AG" pending.

#### Mounting flange:

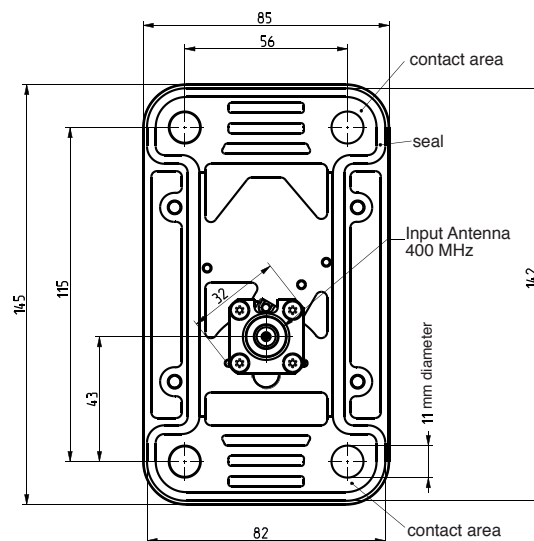

Mounting hole for the connector: 33 mm (max. 35 mm)

**Note:** Mounting surface must be free from paint for electrical contact.

Evenness of opposite surface 0.2 mm.

Use a cap nut plus the enclosed sealing washer.

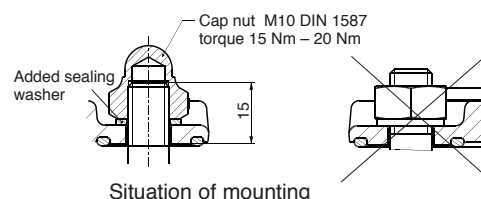



# Vehicular antenna

## 406 ... 470 MHz

### K 70 23 21 ., K 70 23 23 .

#### Frequency range 406 – 428 MHz

Typ Nr.	K 70 23 21 0	K 70 23 21	K 70 23 21 1
Input	M 11 x 1 female (the connector for cable RG 58 C/U is supplied).	M 11 x 1 female (the connector for cable RG 213/U is supplied).	N-female
Drill hole dimension	12 mm	12 mm	17 mm
Frequency range	406 – 428 MHz		
VSWR	< 1.7		
Gain	0 dB (ref. to the quarter-wave antenna)		
Impedance	50 Ω		
Polarization	Vertical		
Max. power	50 W (at 50 °C ambient temperature)		
Weight	0.40 kg		
Packing size (outside)	117 x 117 x 114 mm		
Height	70 mm		

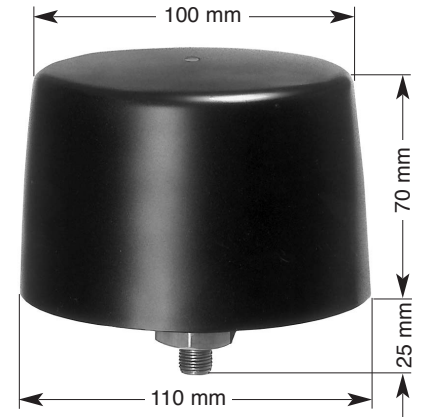

#### Frequency range 440 – 470 MHz

Typ Nr.	K 70 23 23 0	K 70 23 23	K 70 23 23 1
Input	M 11 x 1 female (the connector for cable RG 58 C/U is supplied).	M 11 x 1 female (the connector for cable RG 213/U is supplied).	N-female
Drill hole dimension	12 mm	12 mm	17 mm
Frequency range	440 – 470 MHz		
VSWR	< 1.5		
Gain	0 dB (ref. to the quarter-wave antenna)		
Impedance	50 Ω		
Polarisation	Vertical		
Max. power	50 Watt (at 50 °C ambient temperature)		
Weight	0.40 kg		
Packing size (outside)	117 x 117 x 114 mm		
Height	70 mm		

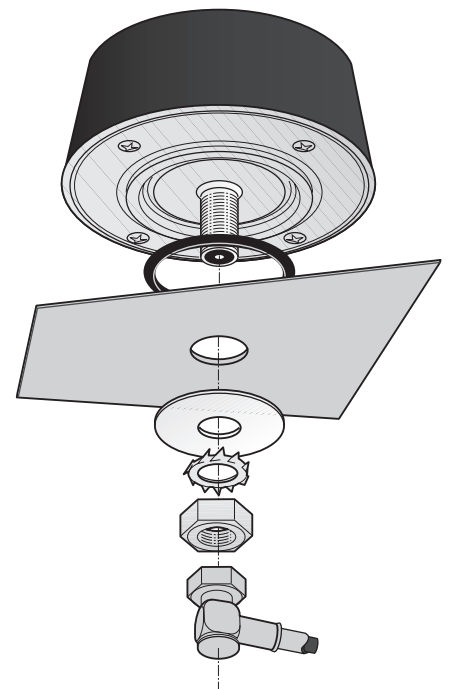

**Material:** Radiator and base: Aluminum.  
Radome: High impact plastic.  
All screws and nuts: Stainless steel.

**Mounting:** On a conductive surface 50 x 50 cm min.  
The drilling diameter is 12 mm except the N connector versions: 17 mm.  
A special zinc washer ensures a good contact at the edges of the hole.

**Special features:** All metal parts of this antenna are D.C. grounded.  
Extreme robust and car-wash proof vehicular antenna.

# Train Antenna 410 – 470 MHz K 70 20 21

- Low profile broadband antenna in fiberglass radome.

Type No.	K 70 20 21
Input	N-female
Frequency range	410 – 470 MHz
VSWR	< 1.5
Gain	0 dB (ref. to the quarter-wave antenna)
Impedance	50 Ohm
Polarization	Vertical
Max. power	170 W (at 50° C ambient temperature)
Weight	0.5 kg
Packing size (outside)	151 x 87 x 210 mm

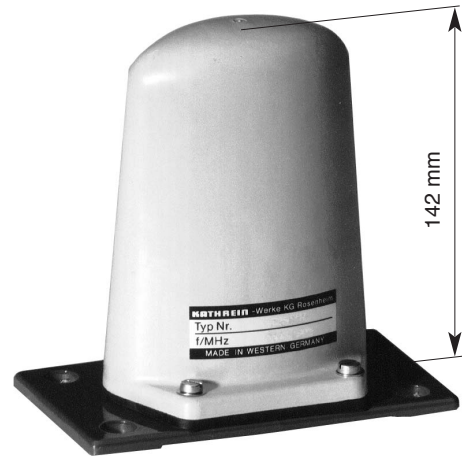

**Material:** Radiator and Flange: Aluminum.  
Radome: Fiberglass, colour: Light grey.  
All screws and nuts: Stainless steel.

**Mounting:** On a conductive surface with a minimum size of 50 x 50 cm by means of existing M10 studs.

**Grounding and high voltage protection:** This antenna approved by the "Deutsche Bahn AG" is D.C. grounded to protect against lightning and high-tension lines.

**Mounting flange:**

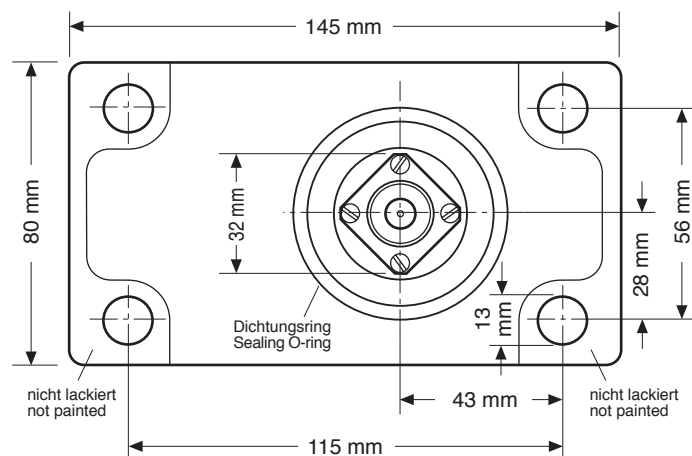

**Mounting hole for the connector:** 33 (max. 35) mm diameter.  
**Note:** Keep mounting surface clear of paint for electrical contact.

# Train Antenna

## 410 – 430 / 450 – 470 MHz

### K 70 21 21, 725 892

- 2 dB gain broadband antenna in fiberglass radome.

Type No.	K 70 21 21	725 892
Input	N-female	
Frequency range	450 – 470 MHz	410 – 430 MHz
VSWR	< 1.5	
Gain	2 dB (ref. to the quarter-wave antenna)	
Impedance	50 Ohm	
Polarization	Vertical	
Max. power	640 W (at 50° C ambient temperature)	
Weight	0.8 kg	
Packing size (outside)	151 x 90 x 415 mm	

**Material:** Radiator and Flange: Aluminum.  
Radome: Fiberglass, colour: Light grey.  
All screws and nuts: Stainless steel.

**Mounting:** On a conductive surface with a minimum size of 50 x 50 cm by means of existing M10 studs.

**Grounding and high voltage protection:** This antenna approved by the "Deutsche Bahn AG" is D.C. grounded to protect against lightning and high-tension lines.

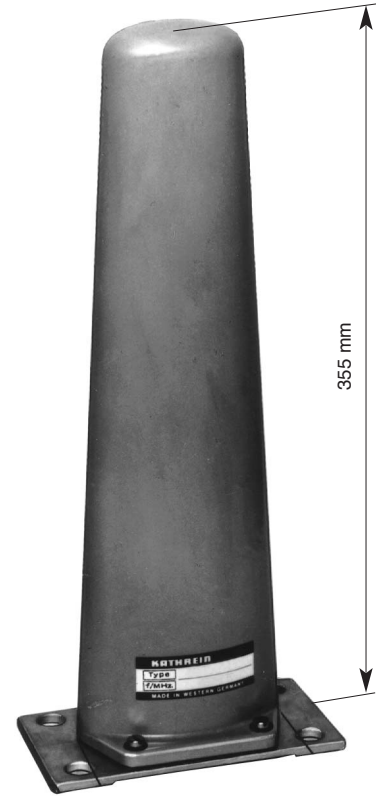

**Mounting flange:**

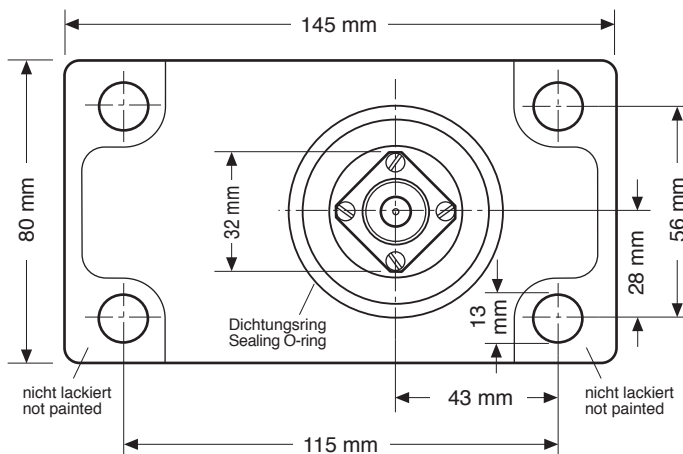

Mounting hole for the connector: 33 (max. 35) mm diameter.

**Note:** Keep mounting surface clear of paint for electrical contact.

# Low Silhouette Train Antenna

## 444 ... 470 MHz

### 729 003, 721 232

- 0 dB antenna of very low profile in fiberglass radome.

Type No.	729 003	721 232
Input	N female	N female
Frequency range	444 – 461.5 MHz	457 – 470 MHz
VSWR	< 1.7 (444 – 461.5 MHz) < 1.5 (448 – 458 MHz)	< 1.5
Gain	0 dB (ref. to the quarter-wave antenna)	
Impedance	50 Ω	
Polarization	Vertical	
Max. power	50 W (at 50 °C ambient temperature)	
Weight	0.65 kg	
Packing size (outside)	137 x 92 x 174 mm	

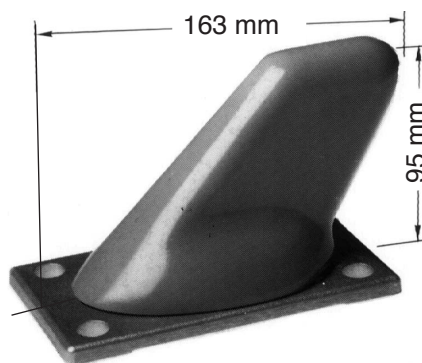

- Material:** Base: Aluminum.  
Radiator: Aluminum.  
Radome: Fiberglass; Colour: Grey.  
All screws and nuts: Stainless steel.
- Mounting:** On a conductive surface of a minimum size of 50 x 50 cm by means of 4 existing M10 studs.
- Grounding and high voltage protection:** This antenna is D.C. grounded to protect against lightning and high-tension lines.

#### Mounting flange:

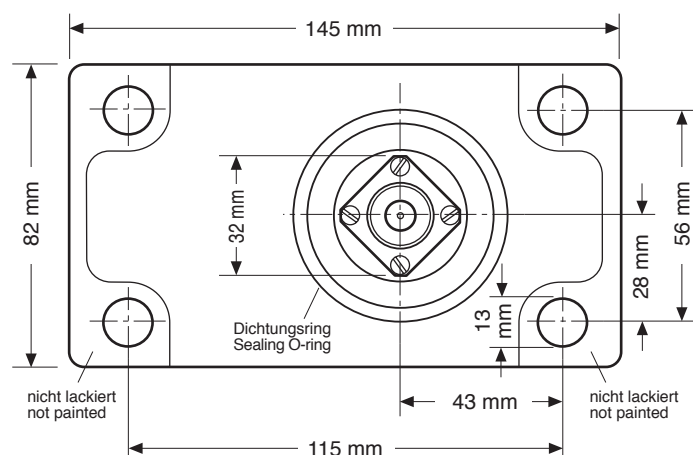

- Mounting hole for the connector: 33 (max. 35) mm diameter.  
**Note:** Keep mounting surface clear of paint for electrical contact.



# Train Antenna

## 450 – 470 MHz and 806 – 960 MHz

### K 70 20 61

- Two-band antenna in fiberglass radome working in the 450 – 470 MHz and 806 – 960 MHz range.
- The antenna can be operated in both frequency ranges simultaneously by using the combiner 728 954.

Type No.	K 70 20 61
Input	N female
Frequency range	450 – 470 MHz and 806 – 960 MHz
VSWR	< 1.5
Gain	0 dB (ref. to the quarter-wave antenna)
Impedance	50 Ω
Polarization	Vertical
Max. power	500 W (at 50 °C ambient temperature)
Weight	0.5 kg
Packing size (outside)	151 x 87 x 210 mm

**Material:** Radiator: Brass.  
Flange: Aluminum.  
Radome: Fiberglass; Colour: Light grey.  
All screws and nuts: Stainless steel.

**Mounting:** On a conductive surface with a minimum size of 50 x 50 cm by means of 4 existing M10 studs.

**Grounding and high voltage protection:** This antenna approved by the "Deutsche Bahn AG" is D.C. grounded to protect against lightning and high-tension lines.

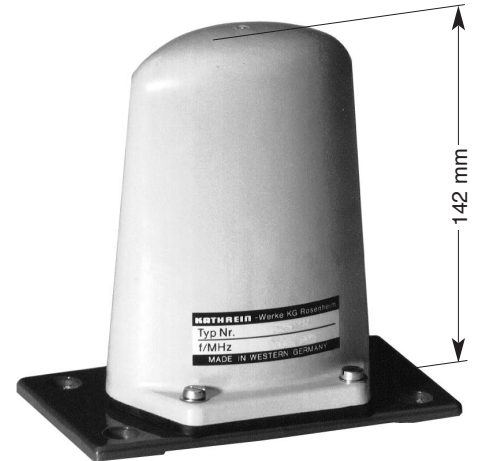

### Accessories: Combiner (order separately)

Type No.	728 954
Input	3 x N female
Frequency range:	50 – 1000 MHz
Input 1	50 – 470 MHz
Input 2	870 – 1000 MHz
Impedance	50 Ω
Insertion loss	< 0.5 dB
Input 1 → Output	< 0.4 dB (typ. 0.3 dB)
Input 2 → Output	< 0.5 dB (typ. 0.4 dB)
Coupling loss	
Input 1 ↔ Input 2	> 45 dB

Mounting flange:

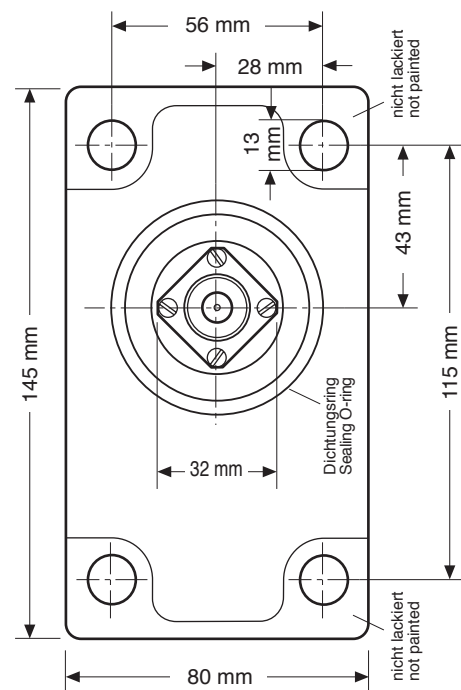

Mounting hole for the connector:  
33 (max. 35) mm diameter.

**Note:** Keep mounting surface clear of paint for electrical contact.

# Train Antenna

## 430 – 470 MHz and 870 – 960 MHz

### 870 10009

- Two-band Antenna: 430 – 470 MHz / 870 – 960 MHz
- Low profile antenna in fiberglass radome.
- The antenna fulfils the requirements according to EN 50155.

Type No.	870 10009
<b>Antenna two-band</b>	
Input	N female
Frequency range	430 – 470 MHz 870 – 960 MHz
VSWR	< 1.5
Gain	0 dB (ref. to the quarter-wave antenna)
Impedance	50 Ω
Polarization	Vertical
Max. power	100 W (at 50° C ambient temperature)
Inner conductor	D.C. grounded
Weight	Approx. 0.5 kg
Packing size, L x W x H	150 x 90 x 190 mm
Height	150 mm

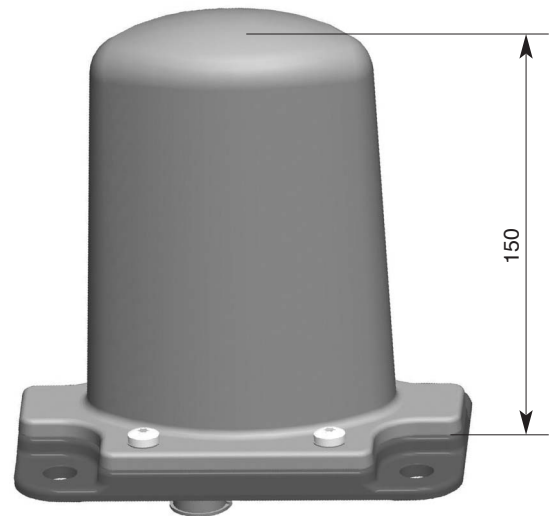

- Material:** Radiator: Copper and brass.  
Flange: Aluminum. Radome: Fiberglass.  
All screws and nuts: Stainless steel.  
Colour: Grey.
- Mounting:** On a conductive surface with a minimum size of 1000 mm x 1000 mm by cap nut only on 4 existing M10 studs.
- Grounding:** This antenna is D.C. grounded to protect against lightning and high-tension lines.  
Approval according to "Deutsche Bahn AG" pending.

Mounting flange:

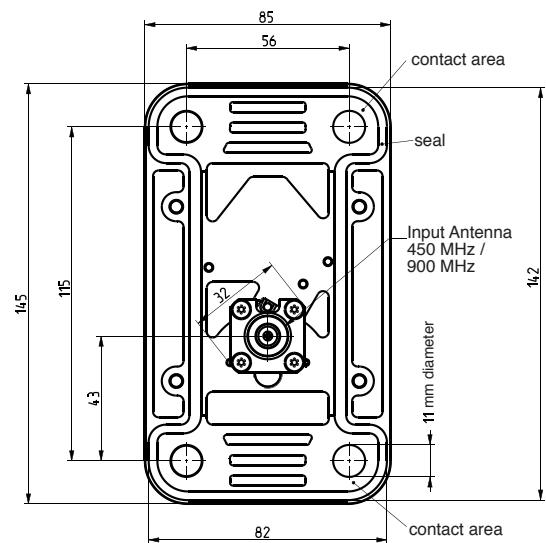

Mounting hole for the connector: 33 mm (max. 35 mm)

**Note:** Mounting surface must be free from paint for electrical contact.

Evenness of opposite surface 0.2 mm.

Use a cap nut plus the enclosed sealing washer.

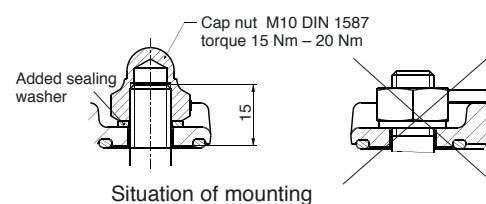

# Train Antenna 870 – 960 MHz 741 009

- Broadband antenna of very low profile in fiberglass radome.

Typ Nr.	741 009
Input	N-female
Frequency range	870 – 960 MHz
VSWR	< 1.5
Gain	0 dB (ref. to the quarter-wave antenna)
Impedance	50 Ω
Polarization	Vertical
Max. power	100 W (at 50 °C ambient temperature)
Weight	0.5 kg
Packing size (outside)	137 x 92 x 174 mm

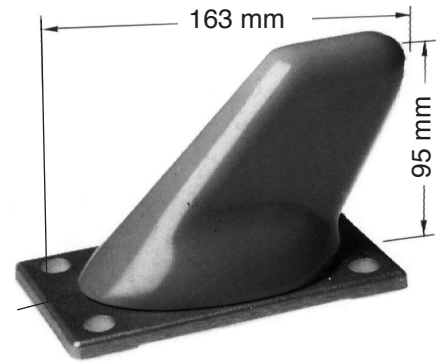

**Material:** Radiator: Brass.  
Flange: Aluminum.  
Radome: Fiberglass; Colour: Light grey.  
All screws and nuts: Stainless steel.

**Mounting:** On a conductive surface of a minimum size of 50 x 50 cm by means of 4 existing M10 studs.

**Grounding and high voltage protection:** This antenna approved by the "Deutsche Bahn AG" is D.C. grounded to protect against lightning and high-tension lines.

Mounting flange:

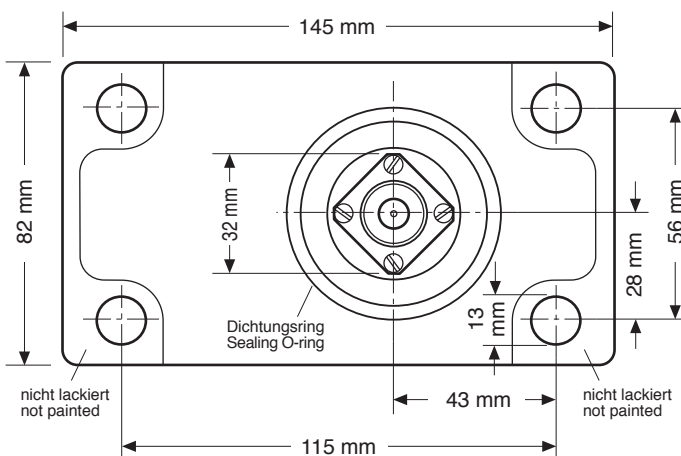

Mounting hole for the connector: 33 (max. 35) mm diameter.  
**Note:** Keep mounting surface clear of paint for electrical contact.

# Train Antenna

## 876 – 960 MHz

### K 70 21 63 1

- Broadband gain antenna in fiberglass radome.

Type No.	K 70 21 63 1
Input	N female
Frequency range	876 – 960 MHz
VSWR	< 1.5
Gain	3.5 dB (ref. to the quarter-wave antenna)
Impedance	50 Ω
Polarization	Vertical
Max. power	500 W (at 50 °C ambient temperature)
Weight	1 kg
Packing size (outside)	151 x 90 x 415 mm

**Material:** Radiator: Brass.  
Flange: Aluminum.  
Radome: Fiberglass; Colour: Light grey.  
All screws and nuts: Stainless steel.

**Mounting:** On a conductive surface with a minimum size of 50 x 50 cm by means of 4 existing M10 studs.

**Grounding and high voltage protection:** This antenna approved by the “Deutsche Bahn AG” is D.C. grounded to protect against lightning and high-tension lines.

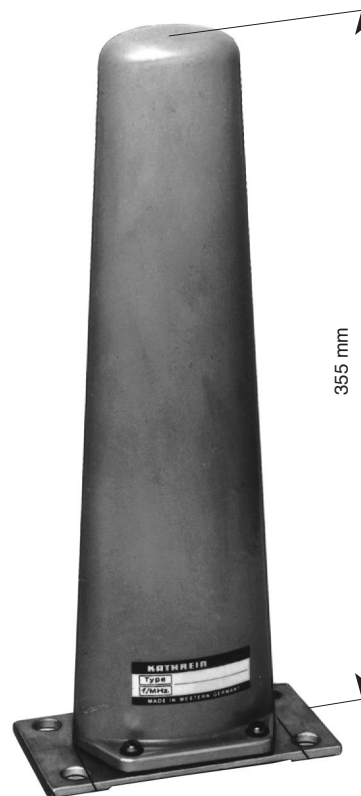

**Mounting flange:**

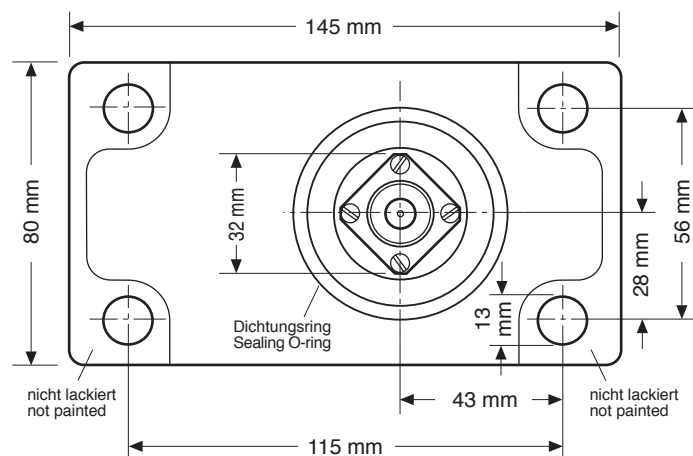

**Mounting hole for the connector:** 33 (max. 35) mm diameter.  
**Note:** Keep mounting surface clear of paint for electrical contact.



# Train Antenna

## 806 – 2700 MHz

### 870 10007

- Multi-band antenna: 800/900/1800/1900/UMTS/UMTS II/W-LAN.
- The antenna can be operated in all frequency ranges simultaneously.
- Low profile antenna in fiberglass radome.
- The antenna fulfils the requirements according to EN 50155.

Type No.	870 10007
<b>Antenna multi-band</b>	
Input	N female
Frequency range	806 – 2700 MHz
VSWR	806 – 870 MHz: < 2.0 870 – 2550 MHz: < 1.5 2550 – 2700 MHz: < 2.0
Gain	0 dB (ref. to the quarter-wave antenna)
Impedance	50 Ω
Polarization	Vertical
Max. power	100 W (at 50° C ambient temperature)
Inner conductor	D.C. grounded
Weight	approx. 0.5 kg
Packing size	152 x 91 x 125 mm
Hight	81 mm

**Material:** Radiator: Copper and brass.  
Flange: Aluminum. Radome: Fiberglass.  
All screws and nuts: Stainless steel.  
Colour: Grey.

**Mounting:** On a conductive surface with a minimum size of 1000 x 1000 mm by cap nut only on 4 existing M10 studs.

**Grounding and high voltage protection:** This antenna is D.C. grounded to protect against lightning and high-tension lines.  
Approval according to "Deutsche Bahn AG" pending.

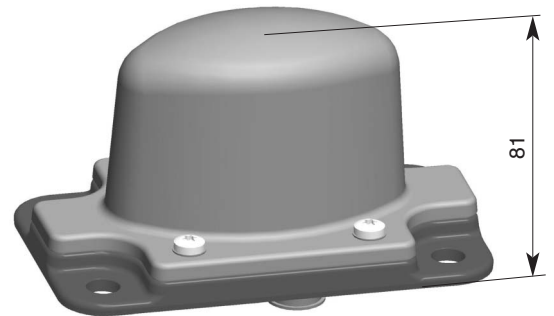

Mounting flange:

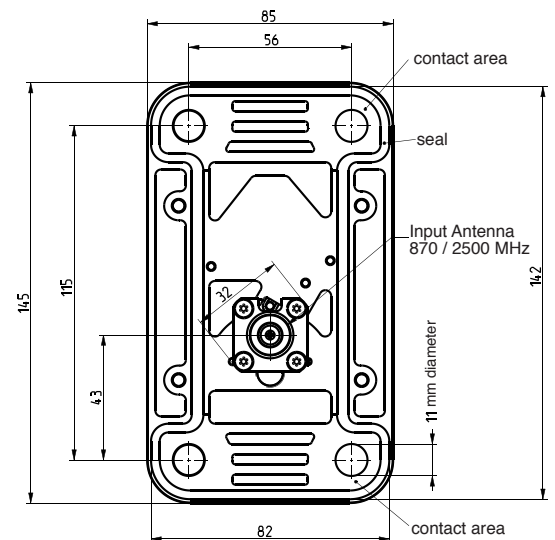

Mounting hole for the connector: 33 mm (max. 35 mm)

**Note:** Mounting surface must be free from paint for electrical contact.

Evenness of opposite surface 0.2 mm.

Use a cap nut plus the enclosed sealing washer.

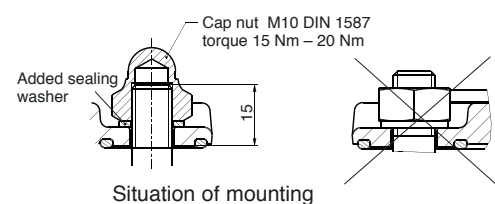

# Train Antenna

## 380 – 430 MHz and GPS 1575 MHz

### 870 10005

- Two-band antenna: 380 – 430 MHz and GPS.
- The antenna can be operated in both frequency ranges simultaneously.
- Low profile antenna in fiberglass radome.
- The antenna fulfils the requirements according to EN 50155.

Type No.	870 10005
<b>Antenna 380 – 430 MHz</b>	
Input	N female
Frequency range	380 – 430 MHz
VSWR	< 1.7
Gain	0 dB (ref. to the quarter-wave antenna)
Impedance	50 Ω
Polarization	Vertical
Max. power	100 W (at 50° C ambient temperature)
Inner conductor	D.C. grounded
<b>Antenna GPS</b>	
Input	Cable RG 316/U of 225 mm length with TNC male connector
Frequency range	1575.42 ±1 MHz
VSWR	< 1.5
Polarization	Right hand circular
Gain (90° elevation)	2 dB (ref. to the circularly polarized isotropic antenna)
Impedance	50 Ω
Inner conductor	D.C. grounded
Weight	Approx. 0.5 kg
Packing size	150 x 90 x 190 mm
Height	150 mm

- Material:** Radiator: Copper and brass.  
Flange: Aluminum. Radome: Fiberglass.  
All screws and nuts: Stainless steel.  
Colour: Grey.
- Mounting:** On a conductive surface with a minimum size of 1000 x 1000 mm by cap nut only on 4 existing M10 studs.
- Grounding** This antenna is D.C. grounded to protect against lightning and high-tension lines.  
Approval according to "Deutsche Bahn AG" pending.
- Accessories:** Low noise amplifier GPS 860 10069 (please order separately).
- Warning:** If the antenna is operated without the pre-amplifier type no. 860 10069, please note the following points.
- Due to the fact that the inner conductor of the antenna GPS is DC grounded, the input of the GPS receiver is loaded with a DC short circuit. If the GPS receiver provides a remote DC power supply, this could damage the GPS receiver.
  - At the input of the antenna GPS a level of –25 dB below the signal applied at the input of the antenna 380 – 430 MHz appears. Depending on the level of the signal applied at the input of the antenna 380 – 430 MHz, the GPS receiver may be overloaded or damaged.

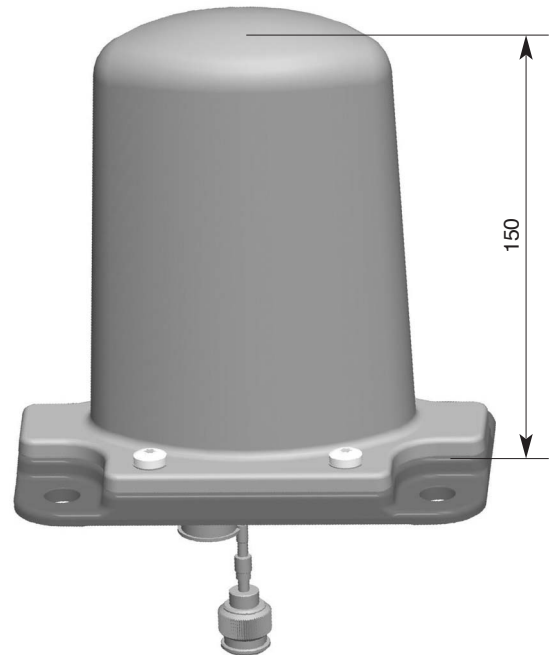

Mounting flange:

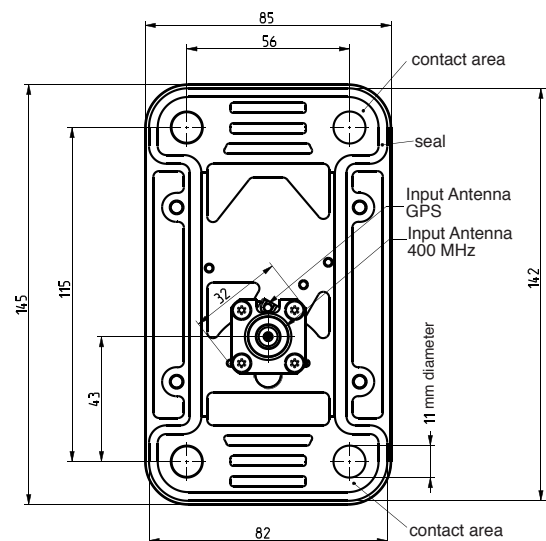

Mounting hole for the connector: 33 mm (max. 35 mm)

**Note:** Mounting surface must be free from paint for electrical contact.

Evenness of opposite surface 0.2 mm.

Use a cap nut plus the enclosed sealing washer.

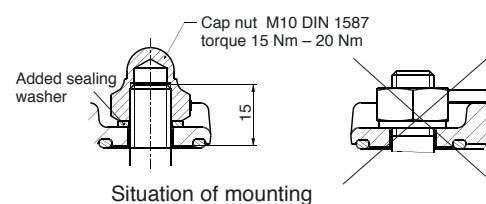

# Train Antenna

## 430 – 470 MHz / 870 – 960 MHz and GPS 1575 MHz 870 10006

- Multi-band antenna: 430 – 470 MHz / 870 – 960 MHz and GPS.
- The antenna can be operated in all frequency ranges simultaneously.
- Low profile antenna in fiberglass radome.
- The antenna fulfils the requirements according to EN 50155.

Type No.	870 10006
<b>Antenna multi-band</b>	
Input	N female
Frequency range	430 – 470 MHz 870 – 960 MHz
VSWR	< 1.5
Gain	0 dB (ref. to the quarter-wave antenna)
Impedance	50 Ω
Polarization	Vertical
Max. power	100 W (at 50° C ambient temperature)
Inner conductor	D.C. grounded
<b>Antenna GPS</b>	
Input	Cable RG 316/U of 225 mm length with TNC male connector
Frequency range	1575.42 ±1 MHz
VSWR	< 1.5
Polarization	Right hand circular
Gain (90° elevation)	2 dB (ref. to the circularly polarized isotropic antenna)
Impedance	50 Ω
Inner conductor	D.C. grounded
Weight	Approx. 0.5 kg
Packing size, L x W x H	150 x 90 x 190 mm
Height	150 mm

- Material:** Radiator: Copper and brass.  
Flange: Aluminum. Radome: Fiberglass.  
All screws and nuts: Stainless steel.  
Colour: Grey.
- Mounting:** On a conductive surface with a minimum size of 1000 x 1000 mm by cap nut only on 4 existing M10 studs.
- Grounding** This antenna is D.C. grounded to protect against lightning and high-tension lines.  
Approval according to "Deutsche Bahn AG" pending.
- Accessories:** Low noise amplifier GPS type no. 860 10069 (please order separately).
- Warning:** If the antenna is operated without the pre-amplifier type no. 860 10069, please note the following points.
- Due to the fact that the inner conductor of the antenna GPS is DC grounded, the input of the GPS receiver is loaded with a DC short circuit. If the GPS receiver provides a remote DC power supply, this could damage the GPS receiver.
  - At the input of the antenna GPS a level of –25 dB below the signal applied at the input of the antenna two-band appears. Depending on the level of the signal applied at the input of the antenna two-band, the GPS receiver may be overloaded or damaged.

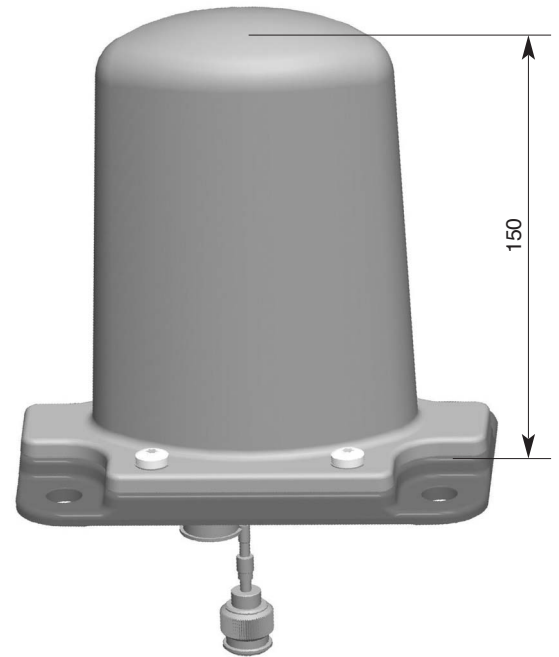

Mounting flange:

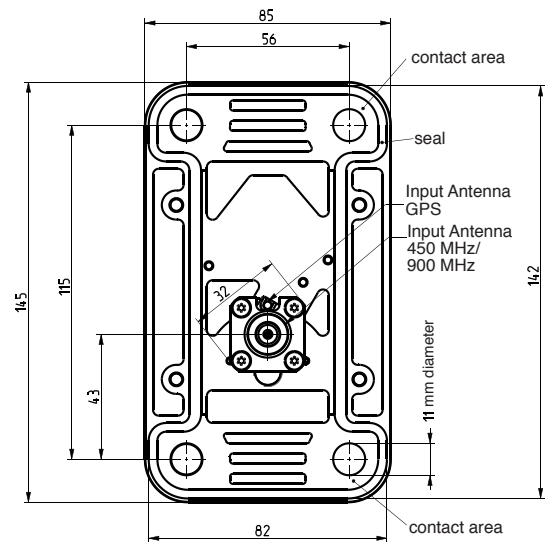

Mounting hole for the connector: 33 mm (max. 35 mm)

**Note:** Mounting surface must be free from paint for electrical contact.

Evenness of opposite surface 0.2 mm.

Use a cap nut plus the enclosed sealing washer.

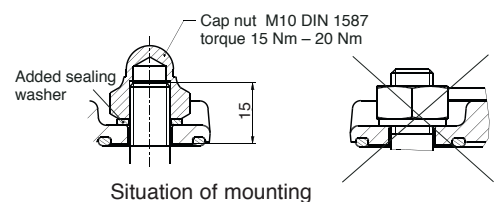

# Train Antenna

## 806 – 2700 MHz and GPS 1575 MHz

### 870 10003

**KATHREIN**  
Antennen · Electronic

- Multi-band antenna: 800/900/1800/1900/UMTS/UMTS II/W-LAN and GPS.
- The antenna can be operated in all frequency ranges simultaneously.
- Low profile antenna in fiberglass radome.
- The antenna fulfils the requirements according to EN 50155.

Type No.	870 10003
<b>Antenna multi-band</b>	
Input	N female
Frequency range	806 – 2700 MHz
VSWR	806 – 870 MHz: < 2.0 870 – 2550 MHz: < 1.5 2550 – 2700 MHz: < 2.0
Gain	0 dB (ref. to the quarter-wave antenna)
Impedance	50 Ω
Polarization	Vertical
Max. power	100 W (at 50° C ambient temperature)
Inner conductor	D.C. grounded
<b>Antenna GPS</b>	
Input	Cable RG 316/U of 225 mm length with TNC male connector
Frequency range	1575.42 ±1 MHz
VSWR	< 1.5
Polarization	Right hand circular
Gain (90° elevation)	2 dB (ref. to the circularly polarized isotropic antenna)
Impedance	50 Ω
Inner conductor	D.C. grounded
Weight	approx. 0.5 kg
Packing size	152 x 91 x 125 mm
Height	81 mm

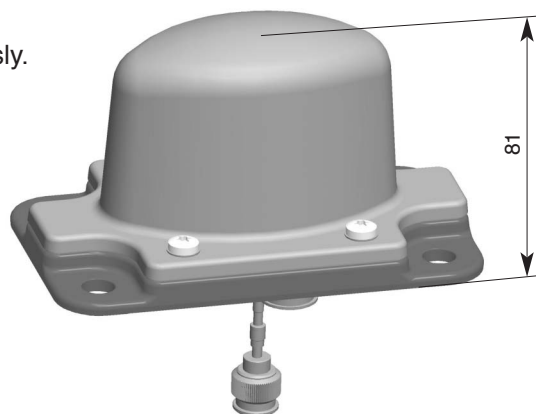

- Material:** Radiator: Copper and brass.  
Flange: Aluminum. Radome: Fiberglass.  
All screws and nuts: Stainless steel.  
Colour: Grey.
- Mounting:** On a conductive surface with a minimum size of 1000 x 1000 mm by cap nut only on 4 existing M10 studs.
- Grounding:** This antenna is D.C. grounded to protect against lightning and high-tension lines.  
Approval according to "Deutsche Bahn AG" pending.
- Accessories:** Low noise amplifier GPS 860 10069 (please order separately).
- Warning:** If the antenna is operated without the pre-amplifier type no. 860 10069, please note the following points.
- Due to the fact that the inner conductor of the antenna GPS is DC grounded, the input of the GPS receiver is loaded with a DC short circuit. If the GPS receiver provides a remote DC power supply, this could damage the GPS receiver.
  - At the input of the antenna GPS a level of –25 dB below the signal applied at the input of the antenna multi-band appears. Depending on the level of the signal applied at the input of the antenna multi-band, the GPS receiver may be overloaded or damaged.

Mounting flange:

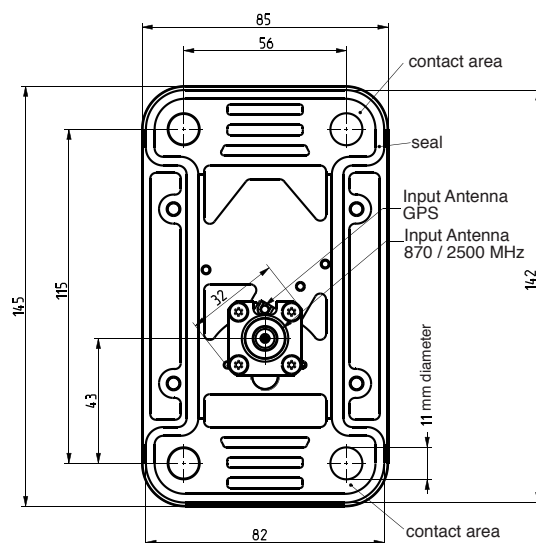

Mounting hole for the connector: 33 mm (max. 35 mm)

**Note:** Mounting surface must be free from paint for electrical contact.

Evenness of opposite surface 0.2 mm.

Use a cap nut plus the enclosed sealing washer.

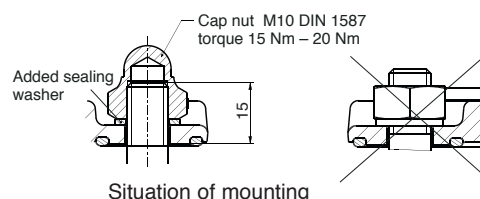



# Low Noise Amplifier GPS 860 10069

- The low noise amplifier 860 10069 is designed for the use with train antennas with GPS.
- It includes a preselection filter to prevent the interference in case of simultaneous operation at the frequency range 380 – 2700 MHz and GPS.
- The product fulfils the requirements according to EN 50155.

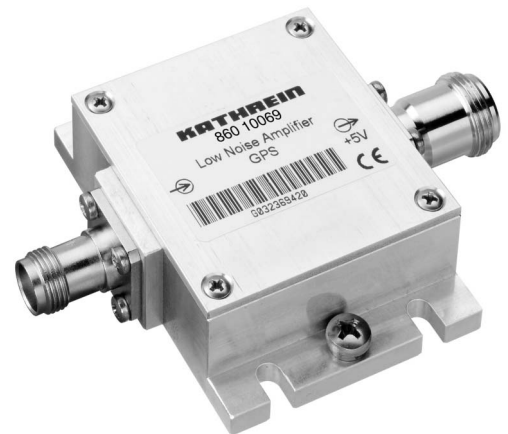

## Block Diagram

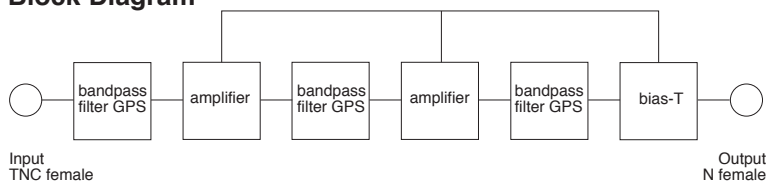

Type No.	860 10069
Frequency	1575.42 MHz, L1-signal
Gain	25 ±2 dB
Noise figure	< 2.0 dB
VSWR (input, output)	< 1.8
Operation voltage	3.0 ... 5.5 V, ripple < 50 mV, supplied at inner conductor RF-output
Operation current	< 40 mA
Connector input	TNC female
Connector output	N female
Dimensions (w x h x l)	70 x 22 x 50 mm
Mounting	4 holes, 4.5 mm diameter

## Additional features:

- The maximum input power at the input of the amplifier at the frequency range 380 – 960 MHz and 1710 – 2700 MHz is limited to +25 dBm.
- The noise level at the GPS-frequency generated by the operation at the frequency range 380 – 960 MHz and 1710 – 2700 MHz should not exceed the thermal noise level at the input of the GPS-amplifier, otherwise the noise figure will be increased.

## Environmental conditions:

- Temperature range: –25 °C ... +45 °C (data as specified)  
–40 °C ... +85 °C (extended range) \*)
- Protection class: IP 54 (DIN 40050 / IEC 144)  
(hanging installation position)

## \*) Extended range of operation:

Within an extended temperature range of –40 °C ... +85 °C and an extended supplied voltage range of 3.2 V ... 6.0 V operation is possible with the following restrictions:

Noise figure: < 2.5 dB

Gain: > 20 dB

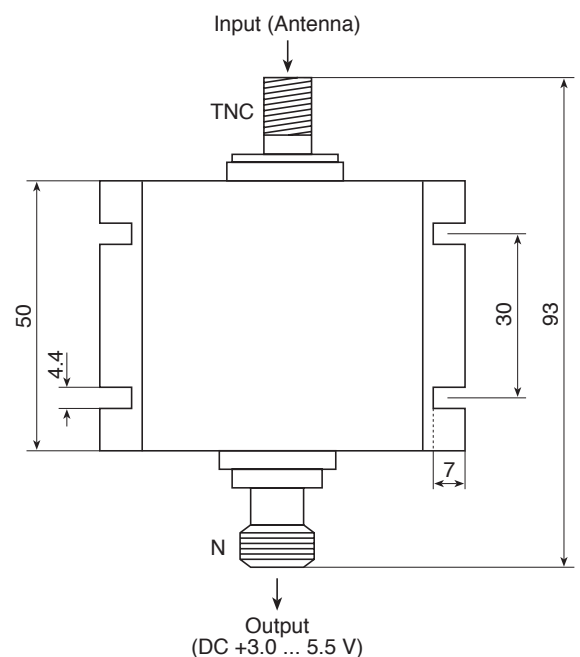
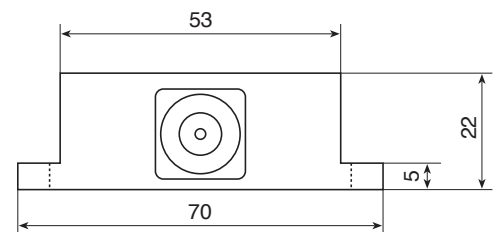

## Abstract

### Quality is the key

Train antennas made by Kathrein are well known as reliable and highly sophisticated products. Our antennas are distinguished by excellent voltage protection against accidentally high voltage contacts due to well developed grounding elements implemented in the overall design.

Train antennas are faced to extreme environmental conditions and need to withstand tremendous operational conditions. The following documents should help to understand functionality and learn more about proper installation procedures.

## Design

Depending on frequency and design constrains Kathrein antennas are designed as  $\lambda/4$  radiators or as  $\lambda/2$  radiators. For proper functionality  $\lambda/4$  radiators have to be mounted on a conductive surface creating a ground plane. Train antennas are usually vertical polarized. Impedance is 50 Ohm.

Kathrein antennas are type approved by the “Deutsche Bahn AG” (German Railway).

Key features of Kathrein antennas to pass the “Deutsche Bahn AG” requirements is the ability to limit connector voltage to 60 V in case of contact with the high tension lines. Current flow of 40 kA over a time frame of 100 ms and high voltages of up to 42 kV could be applied under worst case conditions.



68 – 87,5 MHz



410 – 470 MHz



Broadband + GPS  
(incl. amplifier)

## Installation

### Ground Plane

Fundamental RF basics require metallic surfaces for certain antenna designs. Utilizing  $\lambda/4$  technologies depends on a sufficient ground plane surface to finally distribute RF wave into the surroundings. Thus those particular antennas need to be mounted against a conductive surface to create the required ground plane.

Each data sheet leaves detailed information about surface size. We strongly recommend not to stay under the minimum mounting requirements. Antennas easily will lose VSWR performance, and radiation pattern may change dramatically.

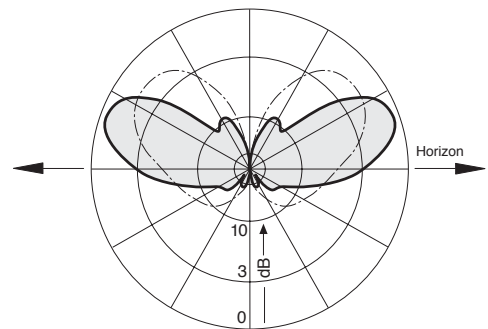
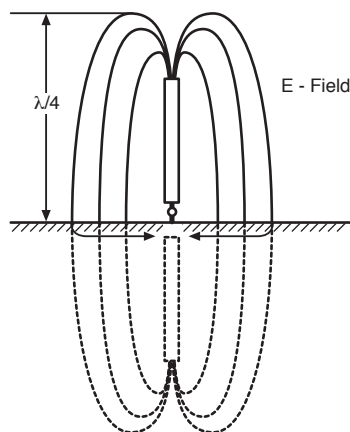

Figure 1: Electrical field and radiation pattern of a  $\lambda/4$  antenna design

#### 3.1.1 Metallic Surfaces

In most of the cases the roof of trains is made out of metallic materials. These materials have a reasonable conductivity to achieve best radiation results. For safety reasons these surfaces need to offer sufficient grounding to finally guide high voltages and currents to the ground.

designs may apply to create such a plane. Metallic foils might be placed underneath a non-metallic train body. Other metals might be laminated into Fiberglass constructions. The antenna flange needs to have good electrical contact to these additional ground planes

#### 3.1.2 Non-Metallic Surfaces

Trains designs appear more and more with non-metallic surfaces mostly present at the front or the end of a train. Apparently those areas are preferred installation areas for antennas.

The same mandatory rule applies as with metallic surfaces: A sufficient grounding of the antenna needs to be considered in the design. Any kind of grounding needs to handle high currents and voltages, and finally lead it to the ground.

As explained previously antennas require ground planes made out of conductive material. Several

## Grounding

In case of an accident or a failure of the high tension line (overhead contact line) high voltage and current might be applied to the antenna. To protect personal and equipment, connector voltage of the antenna is supposed not to exceed 60 V. To guarantee low connector voltages, antenna flanges need to be grounded thoroughly.

- Unpainted areas near the four mounting holes of the antenna flange.

To achieve best conductivity mounting surfaces at the antenna socket and the mating surface of the train should be clean. Any paint residues or other pollution needs to be removed prior to the mounting process.

- In case of non-metallic roof surfaces with an additional ground plane of e. g. thin material, a separate grounding of the antenna mounting flange is required.

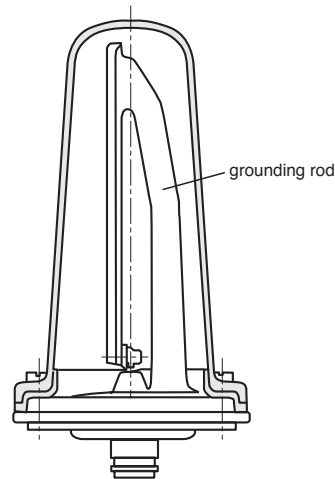

Figure 2: Inside grounding

## Mounting

Most antennas are designed with a standardized foot print of the mounting socket. Dimensions are stated in the data sheets.

### Mounting Sockets

Antenna sockets offer four screw holes to tighten the flange against the mounting surface.

We recommend the following:

- Mounting against a separate flange with integrated mounting bolts. This flange is usually welded to the train.

In general, mounting screws or nuts should not add more than 15 mm to the mounting surface.

In case of an antenna installation with screws through the antenna socket into the vehicle, particular attention should be paid to the sealing of the screws under consideration of the grounding instructions.

### Mounting Position

The antennas have to be mounted directly to the ground plane.

Depending on the overall mounting situation (please refer to “Obstacles close to the antenna”) it’s tempted to elevate antennas against the trains roof with high flanges or other challenging constructions. To avoid mistuning and malfunctioning antennas it is mandatory not to follow these installation ideas. Resonance frequency, radiation pattern, and VSWR would change dramatically or could be lost completely.

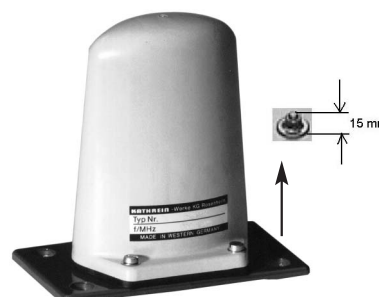

Figure 3: Low profile broad band antenna with mounting screws

---

## Sealing

To avoid corrosion and leaky into the vehicle, antenna connectors need to be sealed against the mounting plate. Every Kathrein antenna is supplied with detailed mounting instructions. An O-ring is supplied with each antenna to seal the through hole into the vehicles body against the antennas connector. To achieve advanced sealing mating surfaces between the antenna socket and mounting

flange/mounting surface are supposed of being flat.

Sealing also needs to be performed around mounting holes if no mounting flanges are used. Corrosion at mating surfaces between the antenna and the mounting plane is critical for proper function of the antenna.

---

## Painting

For optical reasons the color of train antennas sometimes has to match certain colors. Kathrein antennas are particularly suitable for subsequent, long-lasting painting since the visible parts (radomes) are generally made of fiberglass (polyester), to which paint adheres very well. A thin layer of paint eventually has only a negligible influence on the electrical characteristics.

General remarks:

- We recommend that painting is only performed by qualified professional painting companies. If required painting on site may also be possible (and permissible).

- We recommend that painting should only be applied to visible surfaces: e.g.
  - Fiberglass radome
  - Antenna socket, upper surface – please refer to instructions stated in our data sheets

- Suitable commercial paints consist of one or two components. The manufacturer's instruction for use and processing must be observed. Paints with metallic effects or metallic components are not permissible.

---

## Obstacles close to the antenna

For proper wave propagation from the antenna into the surroundings a flat roof without any obstacles would be preferred.

Trains sometimes have a number of structures for multiple purposes on the trains top. Any obstacles close to the antenna may impact radiation pattern and

radiated waves. It is difficult to leave general guidelines about minimum distances. As a rule over the thumb antennas should face no obstacles within a radius of approximately 1 m or more.

---

## Distances to other antennas

The distance to other antennas depends on the required antenna isolation. This value has to be clarified with the suppliers of the installed mobile communication system.

An isolation of 30 dB is a preferred value. As a rule over the thumb, a distance of approximately

5–7 Lambda is required for antennas operating the same frequency band.

Due to the selectivity of different systems, antennas operating in different frequency bands require distances that can be even smaller.





**Please contact for:**

**Sales queries, orders, catalogues  
or CD-ROM:**

Fax: (++49)8031/184-820

E-Mail: [central.sales@kathrein.de](mailto:central.sales@kathrein.de)

**Technical Information:**

Fax: (++49)8031/184-973

E-Mail: [antennas.mobilcom@kathrein.de](mailto:antennas.mobilcom@kathrein.de)

Internet: [www.kathrein.de](http://www.kathrein.de)

KATHREIN-Werke KG · Telephone +49 8031 184-0 · Fax +49 8031 184-973  
Anton-Kathrein-Straße 1 – 3 · P.O. Box 10 04 44 · D-83004 Rosenheim · Germany

**KATHREIN**

Antennen · Electronic